

The Heart-Shaped Display Stand

Here's an easy-to-build weekend project that will make a great accent piece in practically any living room or family room

Here's a perfect, multi-purpose addition for almost any room. Use it in a breakfast nook as a phone stand...in an office for business magazines...in a family room for curios or collectibles... or in a bedroom for treasured family photos. The list goes on.

We're sure that once you've built one of these for yourself and discovered how quick and easy it was, you'll want to "whip out" a few more for your favorite family members and friends. In fact, this is one of those instances where you might want to consider this carefully before you buy your materials. Remember, with certain projects, it's often just as easy to make six of something as it is to make just one!



Our example features heart-shaped shelves and was made out of cherry. However, it could just as easily have more contemporary, triangular-shaped shelves and be built out of black lacquered poplar. Modifying this plan is a "breeze". So, let's get started:

1. Joint and glue-up the stock for the shelves (A). Use regular Bar Clamps...or, to minimize sanding by ensuring the evenness of board surfaces during glue-up, use Double Bar Clamps. They're designed to clamp the boards together while keeping all surfaces flush while the glue dries (in this case, allow 24 hours before proceeding).
NOTE: Don't forget to use a damp cloth to wipe off any glue squeeze-out before it dries on project surfaces. Glue on workpiece surfaces will prevent your stains or other finishes from *taking* evenly.
2. Examine your stock carefully once the glue has dried. If you've missed a couple of spots of squeeze-out, now is the time to remove them before proceeding. The best tool for this is a Hand Scraper. Once you've removed the surface glue from your stock, use your Thickness Planer or Belt Sander to bring it to a final thickness of 3/4".
3. Lay out one heart-shaped shelf on your stock and rough cut it out of the stock (**Fig. 1**).
4. Cut out the two remaining shelf blanks. Stack them together (with Double-Stick Tape between each)...placing the one containing the drawn heart-shaped design on top.
5. Use your Bandsaw and the *Pad-Sawing* technique to cut out all three identical shelves (A), at once.
6. While the three shelves are still taped together, set up your MARK V in Disk Sander mode and sand the three 1-5/8" long *Flats* for the Legs, as shown in **Fig 2**.

7. Again, while the shelves are still taped together, use a Strip Sander or one of Shopsmith's all-new, 6" long Drum Sanders to sand the outside edges smooth to your line. **NOTE:** If you're using a Drum Sander, you'll still have to hand-sand the notch at the top of each heart-shaped shelf.
8. Cut the Legs (B) to size, according to the List of Materials.
9. Following the dimensions shown in **Fig. 3**, use your Dado set-up to cut the 3/4" wide by 1/4" deep shelf support dadoes in the Legs (B).
10. Use your Shaper set-up with a Quarter-Round & Cove Bit — or your Router set-up with a 1/4" Router Chuck and 3/8" Round-Over Bit to round-over your shelf edges. **NOTE: Be careful not to round-over in the three areas where the Shelves (A) attach to the Legs (B).**
11. Counterbore 3/8" diameter x 1/4" deep holes on the outside of the Legs (B), centered over your dadoes (**Fig. 3**), then drill through for the screw shanks.
12. Assemble the Stand as shown in **Fig. 4** using 1-1/2" x #6 wood screws. Cover the screw heads with dowel hole plugs and sand flush.
13. Apply the finish of your choice and enjoy!

List of Materials

(finished dimensions in inches)

A	Shelves (3)	3/4 x 12 x 12
B	Legs (3)	3/4 x 1-5/8 x 30-1/2

Miscellaneous:

- (9) 1-1/2" x #6 wood screws
- (9) 3/8" dia. dowel hole plugs

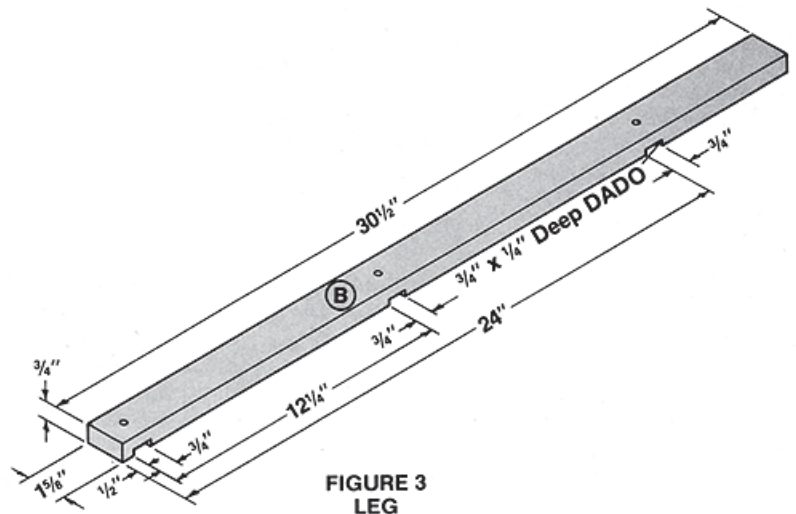

FIGURE 3
LEG

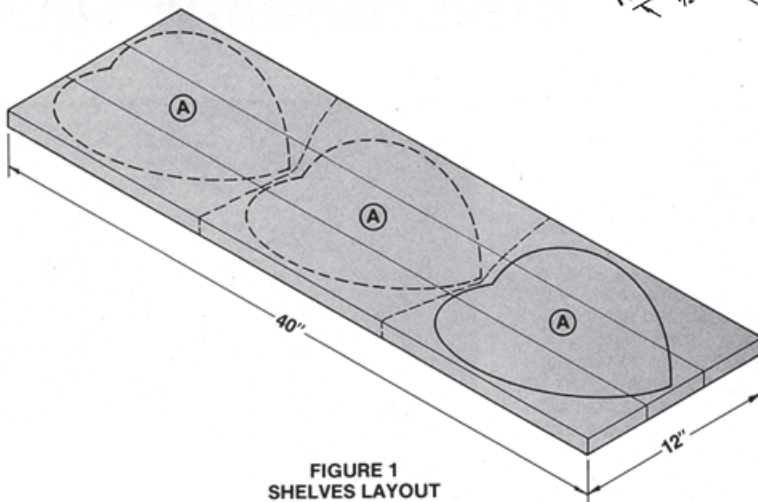
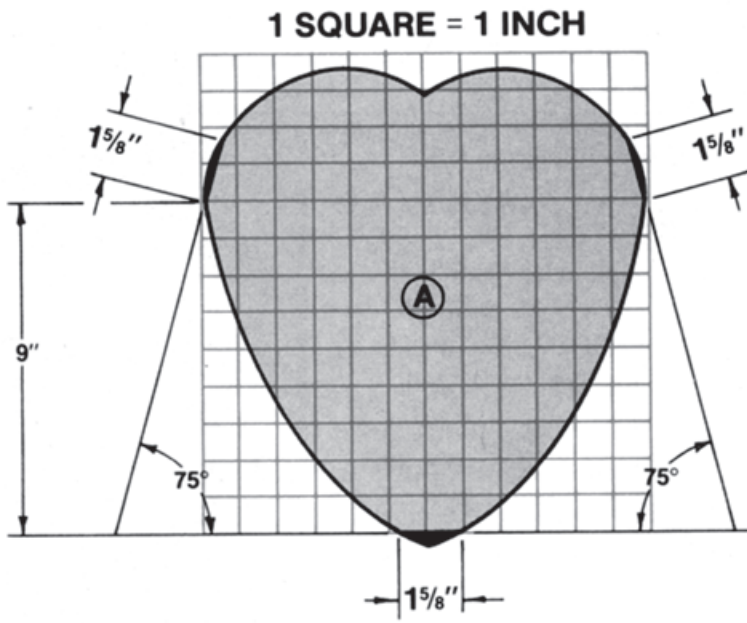
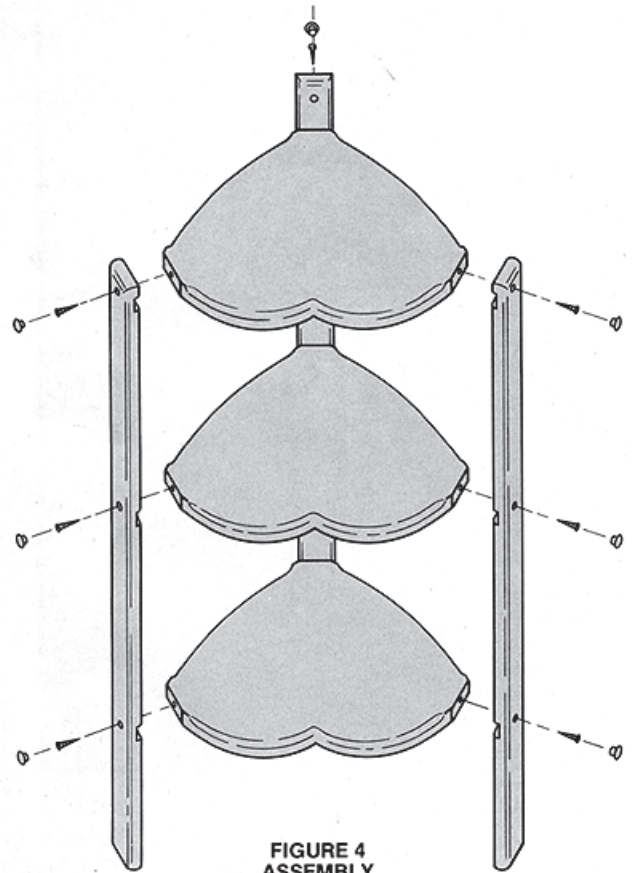

FIGURE 1
SHELVES LAYOUT



**FIGURE 2
SHELF DESIGN**



**FIGURE 4
ASSEMBLY**